

## FE 24/7 2.5

Mobile unit for continuous welding application and for one or two users. Fumes extracted directly at the torch.



The FE 24/7 2.5 is a mobile high vacuum unit designed to extract welding fumes in a continuous basis. Connected to a welding torch with integrated extraction, the FE 24/7 2.5 unit extracts the fumes directly at source for one or two welders. Automatic filter cleaning, side channel fans with high capacity and all special values that a Nederman product offers.

Upgrade with automatic start/stop function is available for user-friendly operation and improved energy efficiency.

The unit comes with 5m electric cable with CEE plug.



- Fumes are extracted efficiently during long shifts of welding thanks to the continuous run, efficient and maintenance-free side channel blower.
- Easy adjustment of air flow depending on application improves productivity and energy efficiency.
- Efficient and automatic filter cleaning assures long filter life for low operating cost.
- Integrated spark trap protects the FE 24/7 from sparks and minimizes the risk of damages to the filter cartridge.
- Filtered air can be re-circulated even when particulates are from high alloy steel (EN 15012).

Product name	FE 24/7 2.5
Noise level (dB(A))	73
Filter efficiency (%)	99
Installation	[Indoor]
Material	Sheet metal
Filter cleaning method	Compressed air
Application	[fumes]
Working pressure (kPa)	37,5
Max Airflow (m3/h)	270
Filter Area (m²)	5
Frequency (Hz)	50 / 60
No of phases	3
Filter type	[cartridge]
Number of filter elements	1
Filter material	Polyester
Electric plug	Euro (CEE 7/2 P+E)
Weight (kg)	59
Power (kW)	2,5
Note	Including 2 x Auto start Stop cable, 2 x 5m x 51mm hose & couplers, 2 x ball valves



Fumes

## FE 24/7 2.5

Image	Description	Power Voltage (V)	Noise level (dB(A))	Model
	FE 24/7 2.5	400	73	55999401
		415	72	676000102*

\*Including 2 x Auto start Stop cable, 2 x 5m x 51mm hose & couplers, 2 x ball valves

## FE 24/7 2.5

Accessory		Part No
	Sensor clamp for welding cable, automatic start/stop.	55999410
	Hose Superflex ø 45mm, black, 5m	55999411
	Hose PE, Black. Ø51mm. 5m	55999412
	Funnel nozzle TM-200	55999413
	Nozzle CWN-S 105/50L silencer, connection D=50 mm, airflow 250 m <sup>3</sup> /h	55999414*
	CWN-S 105/50 nozzle silencer, connection D=50 mm, airflow 250 m <sup>3</sup> /h, suction diameter 105 mm	55999415**
	M50-50P Male coupling Ø 50 mm for hose Ø 50 mm	55999416
	F50-50P Female coupling Ø 50 mm for hose Ø 50 mm	55999417
	M50-44P Male coupling Ø 50 mm for hose Ø 44 mm	55999418
	Magnetic foot for CWN and FWN nozzles	55999419
	Branch coupler BC50-50-50 for two users	55999420
	Ball valve 51mm PVC complete	55999421
	Ball valve 44mm PVC complete	55999422
	Replacement filter cartridge (incl. small filter and plastic bag)	55999430
	Filter for bypass cooling air (set of 5 pcs)	55999431
	Plastic bag for dust bin, 10 pcs	55999432
	Blanking plates FE24/7	55999436

\*Noise reducing nozzle with flexible steel tube extension. For mounting on balance arms, magnet or suction base.

\*\*Noise reducing nozzle. For mounting on balance arms, magnet or suction base.

## FE 24/7 2.5



Accessories configuration for one user, 45mm welding machine connection.

- (1) Hose Coupler M50-44P, art.no. 55999418
- (2) Hose Superflex Ø45mm Black 5m, art.no. 55999411
- (3) Nozzle TM-200 Funnel, art.no. 55999413
- (13) Sensor Clamp with plug for automatic start/stop, art.no. 55999410

## FE 24/7 2.5

Accessories configuration for one user, 50 mm connection:

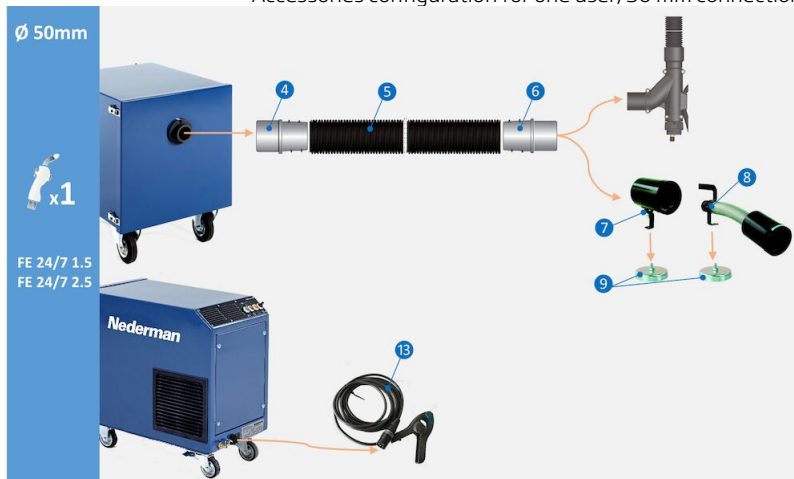

Accessories configuration for one user, 50mm welding machine connection.

- (4) Hose Coupler M50-50P, art.no. 55999416
- (5) Hose PE-51 L=5m, art.no. 55999412
- (6) Hose Coupler F50-50P, art.no. 55999417
- (7) Nozzle CWN-S 105/50 Silencer, art.no. 55999415
- (8) Nozzle CWN-S 105/50L Silencer, art.no. 55999414
- (9) Magnetic foot for nozzle CWN-S, art.no. 55999419
- (13) Sensor Clamp with plug for automatic start/stop, art.no. 55999410

Accessories configuration for two users, 45 mm connection:

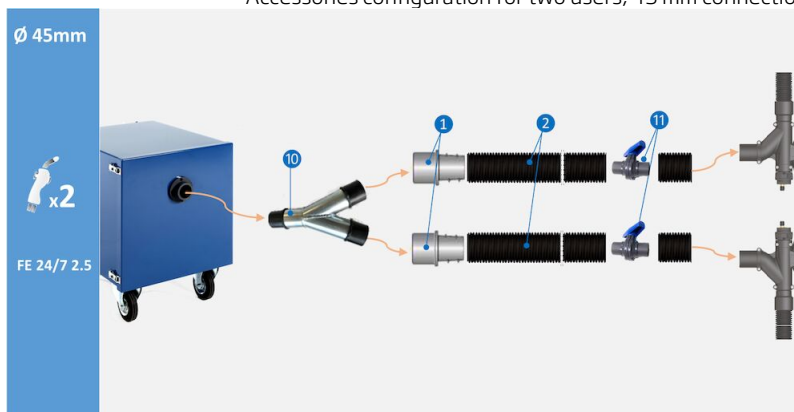

Accessories configuration for two users, 45mm welding machine connection.

- (10) Branch 50/50/50, art.no. 55999420
- (1) Hose Coupler M50-44P, art.no. 55999418
- (2) Hose Superflex Ø45mm Black 5m, art.no. 55999411
- (11) Ball valve 44mm, art.no. 55999422

## FE 24/7 2.5

Accessories configuration for two users, 50 mm connection:

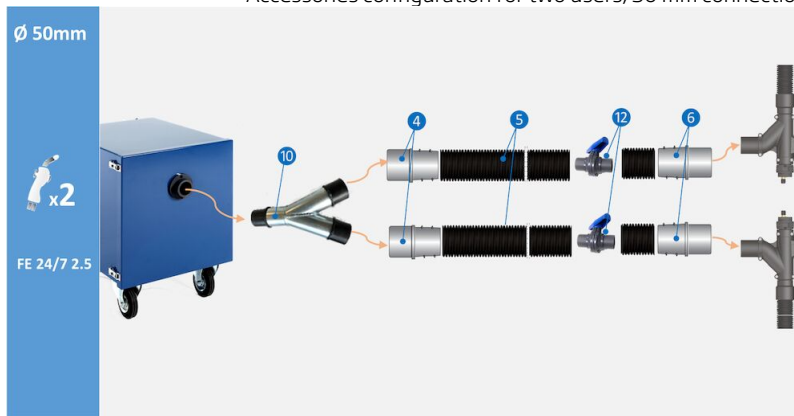

- Accessories configuration for two users, 50mm welding machine connection.
- (10) Branch 50/50/50, art.no. 55999420
  - (4) Hose Coupler M50-50P, art.no. 55999416
  - (5) Hose PE-51 L=5m, art.no. 55999412
  - (12) Ball valve 51mm, art.no. 55999421
  - (6) Hose Coupler F50-50P, art.no. 55999417

